

Design and implementation of a small UAV's pod equipped with a Solid Oxide Fuel Cell

N. Briguglio, G. Giacoppo, O. Barbera, F. Cipiti, M. Ferraro, G. Brunaccini, L. Di Giovanni, N. Randazzo., E. Antonucci.

CNR – ITAE - “Nicola Giordano”, Salita S. Lucia sopra Contesse 5, Messina 98126, Italy,;

Introduction: Design of UAV's pod equipped with a Solid Oxide Fuel Cell (SOFCs) feeds by propane with a maximum power of 200 W. The aim of this study was to calculate the temperature distribution inside the pod, having information about the air intakes' size. The study was developed in the framework of the European project SUAV .

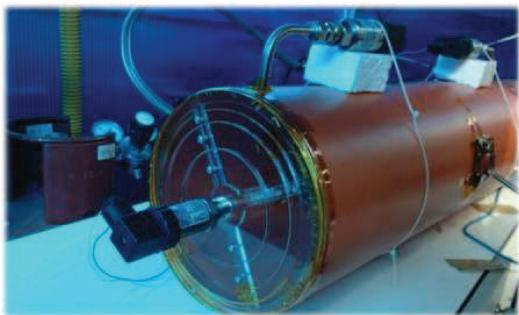

Figure 1. Experimental set up

Computational Methods: A multiphysics approach (turbulent flow and heat transfer) was used. The K-ε turbulent model was used to solve velocity and pressure field. Besides, a mesh depended check was carried out. Based on experimental data, the following boundary conditions were implemented:

Inlet: 1 m/s; *outlet 1:* 0 Pa; *outlet 2 (cathode filter) :* 0.1 m/s; *outlet 3 (fan):* 0.1 m/s; *outlet 4 (fan):* 0.1 m/s; *T1:* 100° C. In this preliminary work, the outlet 1 was considered fully open.

In order to verify the temperature distribution, the test bench was equipped with 16 temperature probes along the tube.

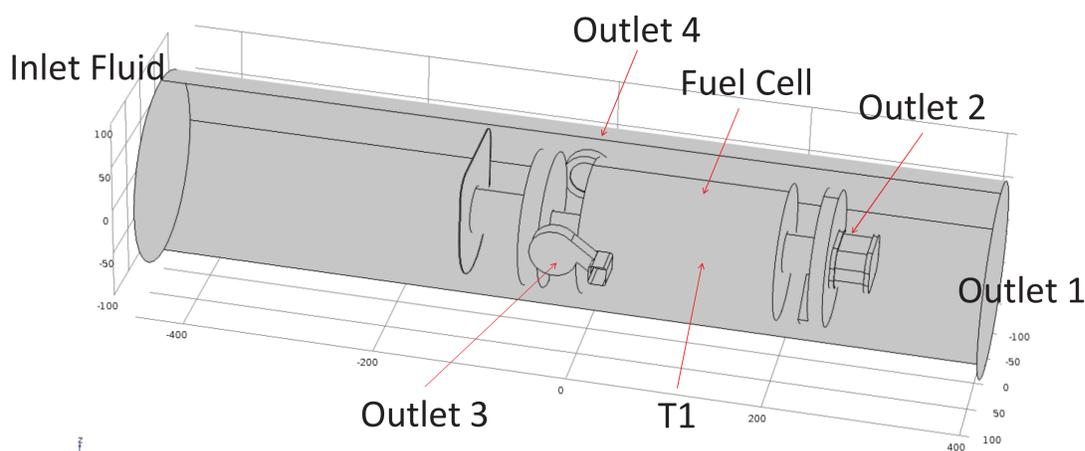

Figure 2. Boundary conditions

Results: Temperature distribution is in accordance with experimental data. Higher temperatures are located in front and at the back of the cathode filter where the velocity field shows recirculation zones.

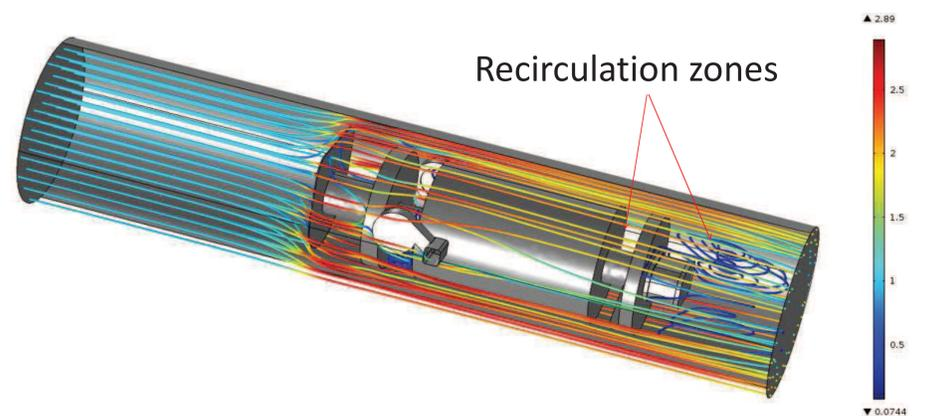

Figure 3. Velocity magnitude [m/s]

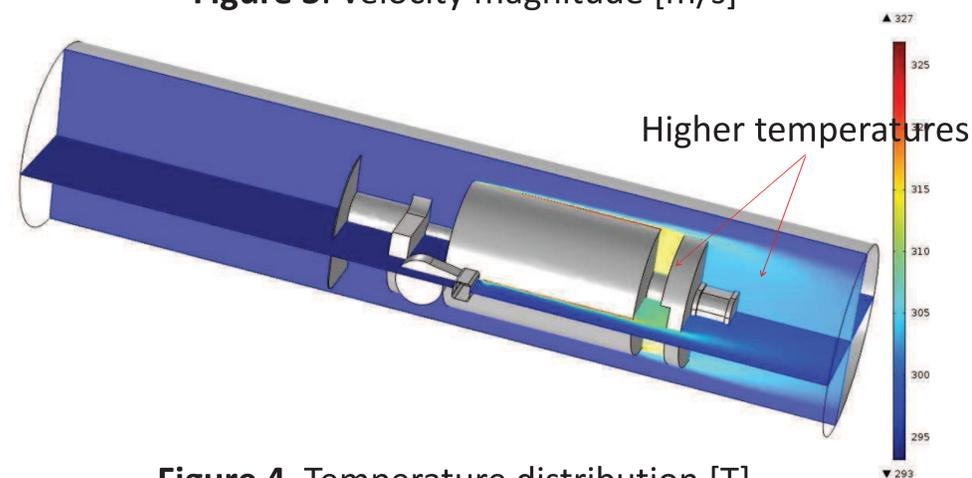

Figure 4. Temperature distribution [T]

Conclusions: This study has permitted to check the simulation results when the outlet 1 is fully opened. Next work will be focused on model validation at different surface area of outlet 1. Finally, the air intakes' size will be designed.

References:

- [1] Frost&Sullivan, 2007, "Study Analysing the Current Activities in the Field of UAV," European Commission - Enterprise and Industry Directorate-General.
- [2] Peng K, Dong M, Chen Ben M, Cai G, Lum KY, Lee TH. Design and implementation of an autonomous flight control law for a UAV helicopter. In: Proceedings of the 26th Chinese control conference, Zhangjiajie, Hunan, China, vol. 6, 2007. p. 662–7.
- [3] S. Saripalli, J.F. Montgomery, G.S. Sukhatme Visually-guided landing of an unmanned aerial vehicle IEEE Trans Robot Automat, 19 (2003), pp. 371–381.
- [4] Cox, T. H., Nagy, C. J., Skoog, M. A., Somers, I. A., and Warner, R., 2004, "A Report Overview of the Civil UAV Capability Assessment," NASA.