

Analytical and Numerical Analysis of Oval-Shaped Composite Beam

A. K. Parkhe¹, R. B. Kapurkar¹, Dr. P. M. Pawar¹

1. SVERI's College of Engineering, Pandharpur, Maharashtra, India

Introduction: Composite materials are widely used in aircraft industries. The composite box-beams are routinely used for the preliminary design of helicopter rotor blades. In this study Carbon Fiber (0₃/90₂/0₃- 8 Layers) composite beam is considered as cantilever type having Oval shape and analysis is carried out.

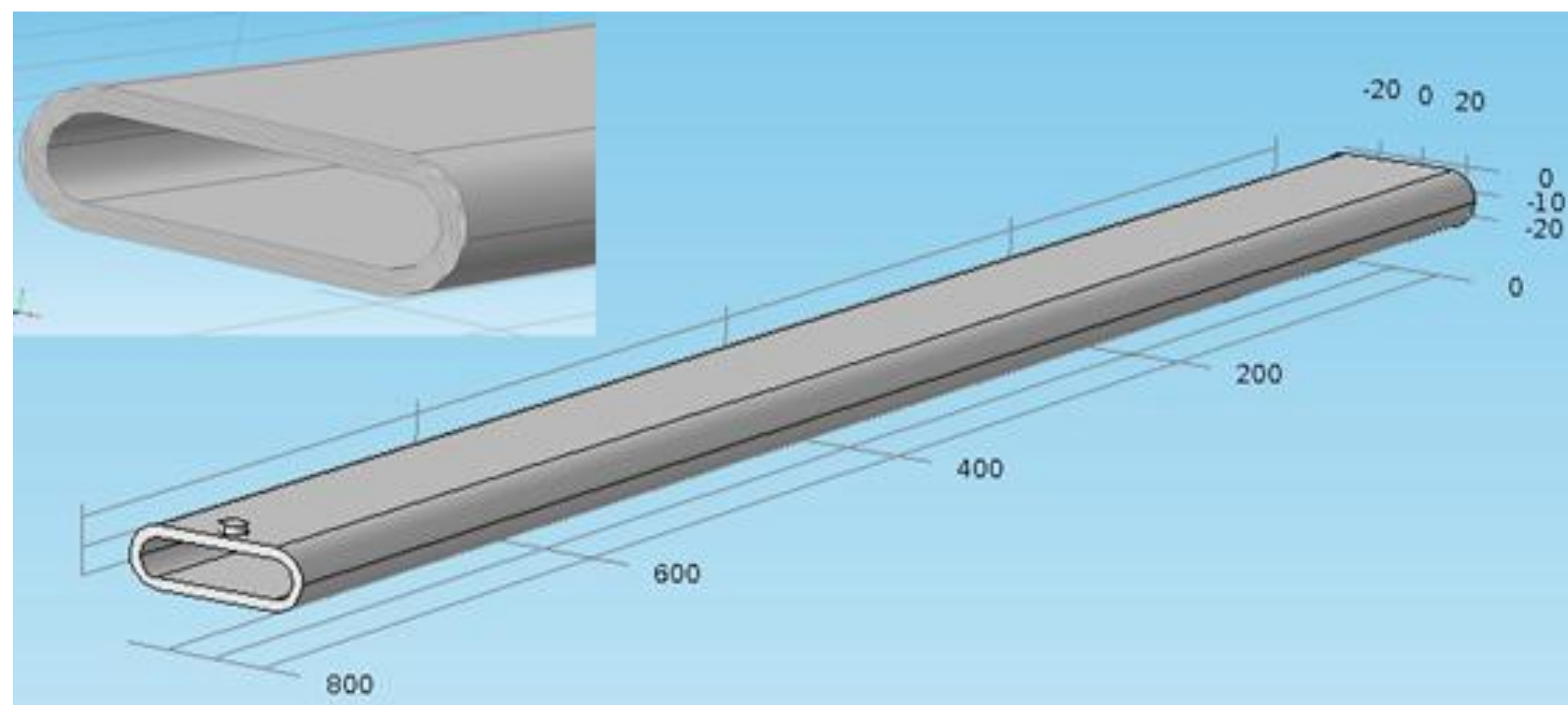

Figure 1. Oval shape Composite beam in COMSOL

Computational Methods: The theoretical analysis is carried out for cantilever type composite Oval shaped beam. In this study beam is fixed at one end and at free end load is applied shown in figure below. There are some formulas are used for theoretical calculations are given below. Simulations are done with the help of COMSOL Multiphysics software and results are compared with analytical study for validation.

$$\delta = \frac{Pl^3}{3EI} \quad Z = \frac{2 \times I}{h}$$

$$\sigma_1 = \frac{P \times L}{Z} \quad \epsilon_1 = \sigma_1/E$$

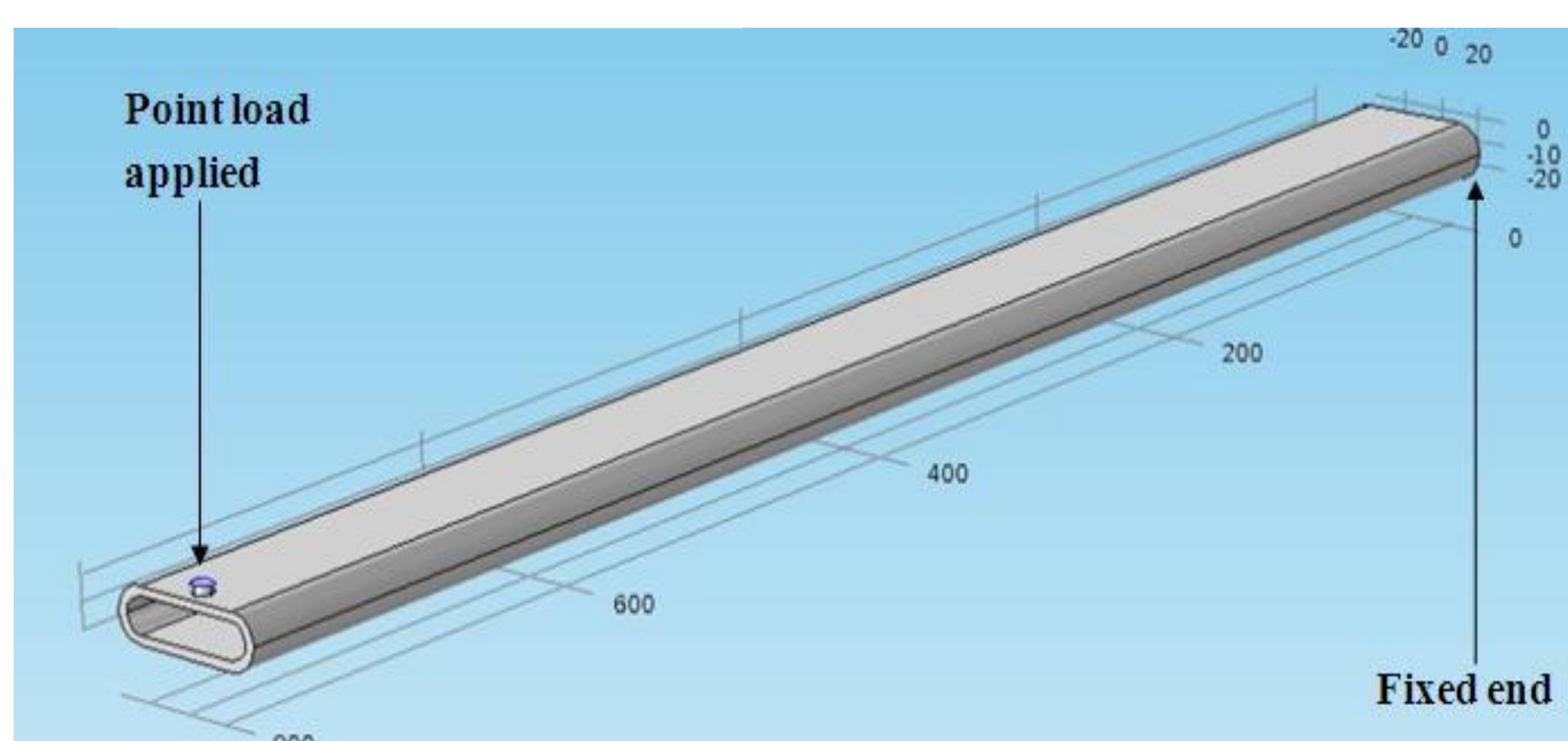

Figure 2. Composite beam with applied Boundary Conditions

Results: The comparison between analytical and simulation results and sample results for Oval shape Composite beam are presented are as follows:

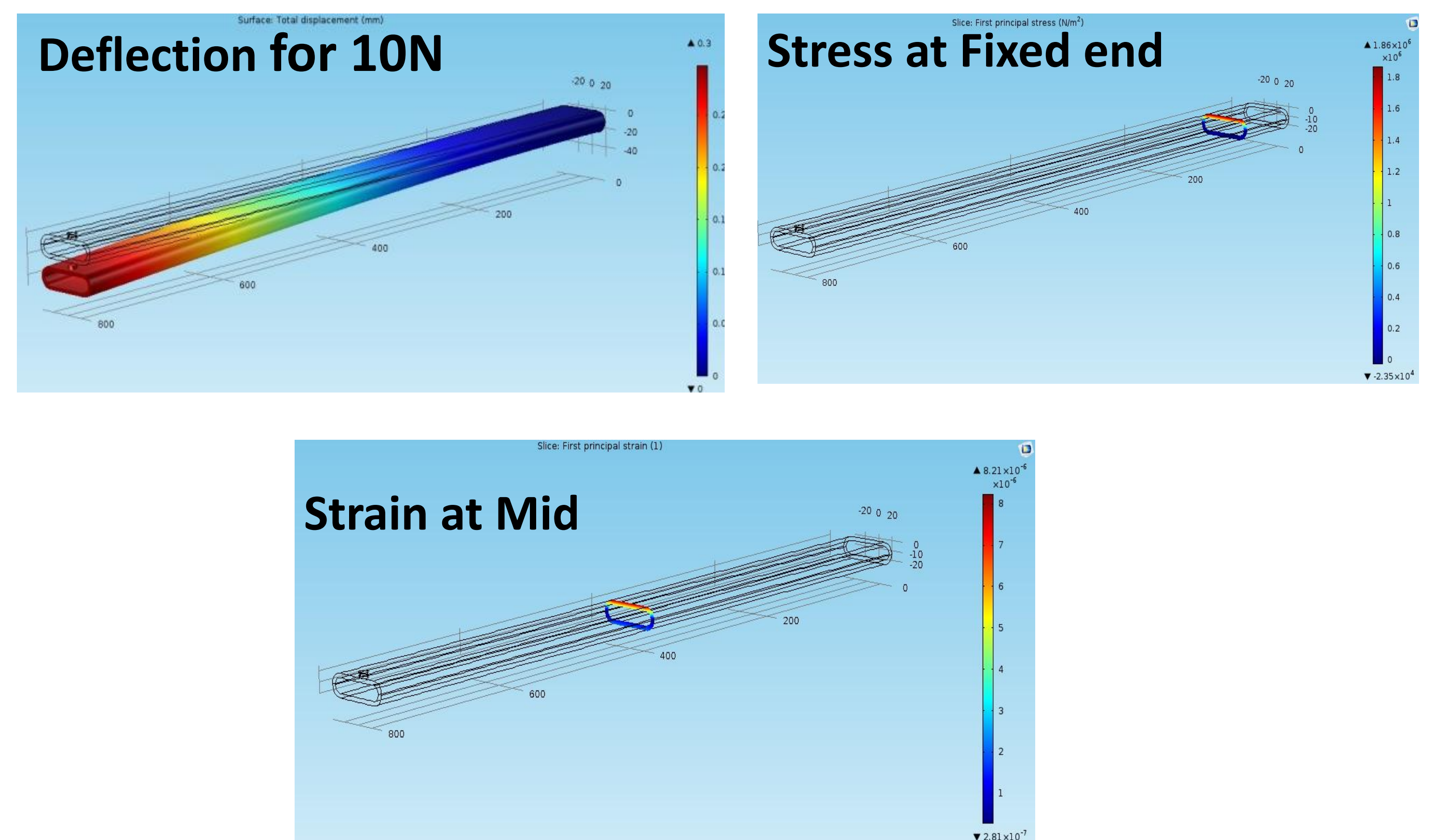

Figure 3. Simulated Sample results for beam using COMSOL

Sr. No.	Force (N)	Simulated Deflection (mm)
1.	10	0.3
2.	20	0.59
3.	30	0.89
4.	40	1.19
5.	50	1.48
6.	60	1.78
7.	70	2.08
8.	80	2.37

Table 1. Deflection at free End of the beam

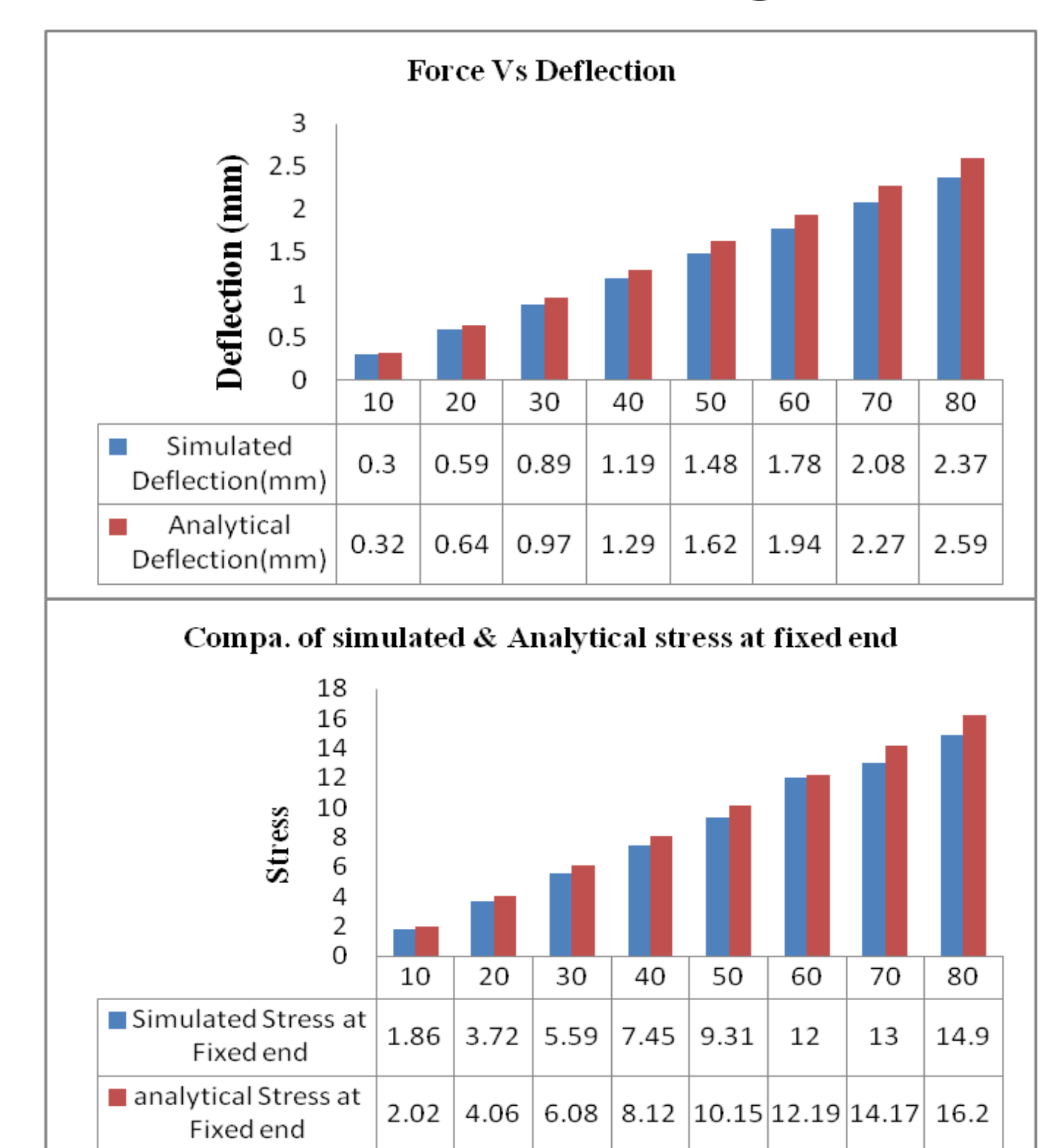

Figure 4. Compared Results For Deflection, Stress & Strain

Conclusions: From the above results, as value of point load increases then deflection at free end, stress-strain at fixed end and mid of beam also increases. Finally, simulated results are compared with analytical results and a percentage error between them is observed within 10%.

References:

1. Pawar, et. al. Eigenvalue Analysis of Composite Box Beam, International Journal of Latest Trends in Engineering and Technology (IJLTET), Vol. 5, 1-5 (2015).
2. Alan Andrew, et. al. Damage Detection On Composite Beam: FEA & Experiment, International Journal of Engineering Research & Technology (IJERT), Vol. 4, 28-39 (2015).