

CFD based optimisation of a laboratory scale silo

A. Egedy¹, A. Radó²

1. Department of Process Engineering, University of Pannonia Organization, Veszprém, Hungary

2. Hamburger Hungária Kft., Dunaújváros, Hungary

Introduction

In the industries, silos are used for the storage of particulate material. Particulate materials often contain a large number of species with uniform or non-uniform size distribution. This classification could include materials from the coarser coal mine debris to fine-powdered sugar. According to some estimation half of the industrial products are in particulate form, as well as the 75% of the reagents. If we include the wheat, iron, cement, sand, etc. in the industries we can see the utmost importance of the silos.

The largest development in the chemical industries began with the oil revolution, and one of the most researched areas is the fluid dynamics, and rheology. The development in solids handling and optimization of storage equipment only began in the last century. Before the equipment's, and devices only designed by empirical ways and the sound numerical foundation of the solid storage design was discovered recently [1].

The simplest way to storage solid materials is to pour it outside on flat surface. However, the outside storage is only a good idea if the material is non-degradable, and resists the environmental conditions. In other cases, the use of some closed equipment is recommended. The biggest storage bunkers are made from concrete and can be built into the ground. The basis could be circular, or rectangular. The advantage of a concrete building is the high carrying capacity. However, the steel constructions often have the advantage of the better wear tolerance.

Silos are solid storage equipment's which has at least 150% height than the base area. Silos can be classified into three classes, mostly based on the capacity [2]. Most of the silos have a circular body and a conical part near the outlet of the silo. Besides the main part inserts are often placed into the silos near the outlet to ensure the optimal outflow. The proper insert could reduce the stresses near the outlet of the silo, as well as lowering the funnelling effect. Triangular and rectangular inserts could also apply to improve the flow characteristics [3]. The dead zones near the outlet could be reduced, or entirely cleared [4].

There are three main flow types during silo discharge: the plug flow, the funnel flow, and the mass flow. Plug flow develops after a great amount of time, when a narrow plug flow starts near the outlet, and slowly reaches the upper region. In case of funnel flow, dead zones are forming near the conical part of the vessel. The mass flow means uniform discharge based on the first in first out (FIFO) principle. Mass flow is the desired flow characteristics during discharge, which can be ensured by the optimization of the silo geometry [5].

In most of the researches, discrete element methods (DEM) can be used for the modelling of silos. DEM treats all the particles as individuals, and calculate the position changes of the particulate system particle by particle based on Newton's second law. Drag, buoyancy, and gravity can also be considered in a detailed DEM model [6, 7]. However, especially in the case of industrial scale devices, the number of particles can be very high (even billions), which lead to the most important flaw of the DEM methods, the high computational demand. Every particle, the forces, and interactions should be calculated in every time step, which is impossible with billion particles even with the advanced parallel or GPU computing techniques.

One solution can be the calculation of a smaller scale device, and try to interpret the characteristics, and conclusions to a larger scale. The other solution can be the use of a Computational Fluid Dynamics (CFD) model, where the solid phase can be treated as a pseudo-plastic fluid, as a non-Newtonian substance. The material parameters can be calculated based on experiments, and the results can be achieved with significantly lower computational time [8].

In this study, a laboratory scale silo was modelled. Our silo is a quasi 2D device, which makes the video recording based validation possible. Different cone angles and the different inserts were applied to the silo, and residence time experiments were performed. A 2D model was implemented in COMSOL Multiphysics, and momentum and component balances were calculated. The model was validated based on the measurements. After the validation, the detailed model was used to achieve optimal insert angle and configuration for uniform discharge.

COMSOL Multiphysics CFD and Chemical Engineering module were used for the CFD simulation. The video processing algorithm and other utility programs were implemented using MATLAB.

Experimental

Figure 1 shows the different silo geometries we applied. The experimental device was made from Plexiglas because the use of the transparent device will make the video recording based model validation possible. The device is a so-called pseudo-2D device, which means the cylinders were replaced by rectangular parts for visualization. In a cylindrical device, the inner changes are not possible to follow, so this approximation often used when video processing based validation applied.

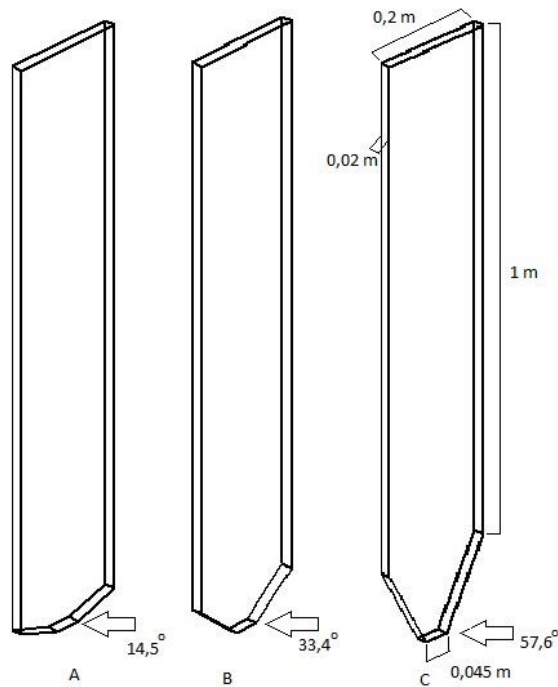

Figure 1 The applied geometries

Three different silo angles were applied (14.5, 33.4 and 57.6°). The upper part of the silos was the same for all cases. The inserts are not included in this picture; they were made by a 3D printer using ABS material for the model validation. Two different plastic particles were used during the experiments, white for the bulk, and black for the tracer layer. Every discharge experiments were recorded, and the movement of the black tracer layer was followed in time using video processing. Using this method residence time of the tracer particles can be calculated for the validation of our simulation results.

Three parallel measurements were performed to ensure the reliability of the experimental results.

Simulation methods

Different geometries and inserts were implemented in a 2D geometry. Figure 2 shows some examples of triangular inserts, the different cone angles, and different insert positions.

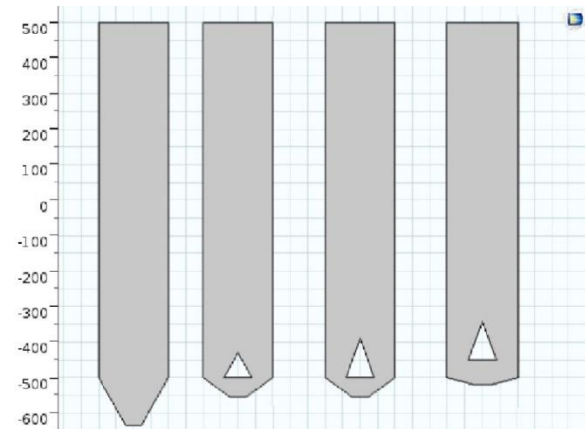

Figure 2 The implemented geometries

Laminar flow interface was used for the momentum balance calculation (Eq 1).

$$\rho \frac{\partial u}{\partial t} + \rho(u \cdot \nabla)u = \nabla \cdot [-pI + \mu(\nabla u + (\nabla u)^T)] + F$$

Eq 1

The density of the plastic was obtained from measurement, while the viscosity was built in using a non – Newtonian approximation. (Eq 2, Eq 3).

$$\mu = m \cdot (\gamma)^{n-1} \text{ Eq2}$$

$$\gamma = \max(\sqrt{D:D}, \gamma_{min}), D = \frac{1}{2}[\nabla u + (\nabla u)^T] \text{ Eq3}$$

The parameters of the model (m, n constants) were identified by simultaneous simulations and comparison to the measurement data. We discuss this process in detail later.

Mass flow was defined as inlet (calculated based on the experiments), while a no stress outlet was defined as the outlet. At first the applicability of no-slip boundary was tested for walls, however, later on, that boundary condition was replaced by slip wall condition because it gave way better agreement with the experimental results.

In case of component balance (for the residence time study) a simple one-component component balance was used with inflow and outflow boundary condition. The component was injected by applying a rectangle function at the inlet, and the integrated concentration was detected at the outlet and used for

the residence time calculation. Stationary momentum balance and the time-dependent component balance were calculated for each different construction. In case of the component balance, the velocity vectors for the stationary momentum balance was used for the time-dependent calculation of the component balance.

Mesh independence and model parameter identification

Two different tests were performed to make sure our model is up to the challenge. The first was a mesh independence test, where different number of mesh elements was applied. The balance difference between the inlet and the outlet flow rates was calculated, and a finer mesh was used for the further calculation. Figure 3 shows the results of the mesh independence calculation, the decrease of the error and the increase of the computational time. As we can see the minimal value of the error is 10% of the maximal, but the maximal balance error is only 0.5 %. Figure 4 shows the chosen mesh (32316 elements).

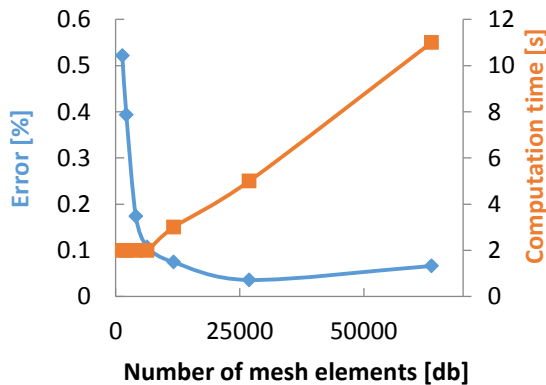

Figure 3. Results of the mesh independence calculation

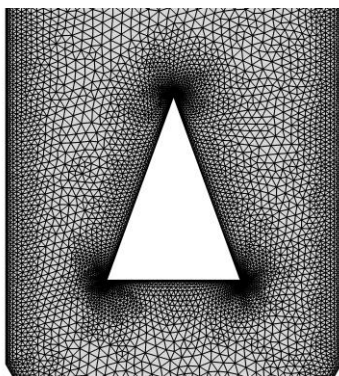

Figure 4. The mesh used for further calculations (insert cross section)

The next step was the identification of the model parameters (m/n). For that step, Livelink to MATLAB was used to manipulate the variables, and run a large number of simulations in loops. The simulation and experimental results were compared to each other, and the sum of absolute difference was calculated for all the different constructions. Figure 5 shows the progress of the indicator impulse at different times (12, 18.3 19.4 s). As we can see with the use of an insert the whole amount of the tracer leaves the silo in a uniform way, which is suitable for the operation of the silo (mass flow).

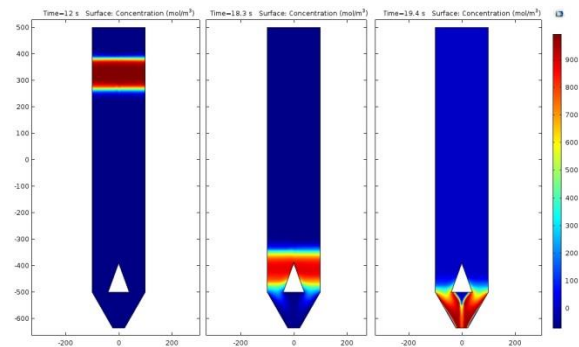

Figure 5. The progress of the indicator impulse through the vessel

Table 1 m/n parameter values

m/n	0,35	0,36	0,37	0,38
3	5,433	5,436	5,439	5,442
4	5,427	5,429	5,432	5,435
5	5,426	5,429	5,432	5,434
7	5,428	5,430	5,434	5,438
9	5,430	5,433	5,436	5,440

Table 1 shows the identified model parameters, while Figure 6 the comparison between the measured, and calculated residence time based on the chosen parameters.

The abbreviations are the following:

- The first letter is for the angle of the silo (l – large, m – medium, s – small).
- The second number tells us about the insert (0 if there is no insert present, 1 while the bigger and 2 while the smaller insert is applied).
- The third letter contains information about the insert position (u – 5 cm-s up, d – down at the baseline of the cylindrical part).

A good agreement was found between the measured, and the simulated values, so we can state our model is validated.

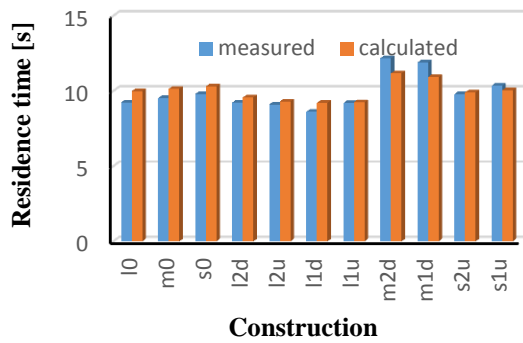

Figure 6. The comparison between measured and simulated values

After the model parameter identification, and the validation of the model we performed simulation aiming at the optimization of the insert angle for different cone angles. Figure 7 and 8 show the results. With the implementation of the triangular inserts, better discharge characteristics can be achieved. There is one additional effect we should discuss, the effect of the dead zone after the insert. Normally, when there is no insert presents the dead zones forms near the walls (left cases). This causes funnel flow, where the solid material stuck and causes non-uniform discharge. The insert caused dead zone, however, is more like an air bubble not containing any solid material, so we lost some percent of the whole capacity of the storage device. However, it is a small cost for the elimination of the funnel flow.

Results and discussion

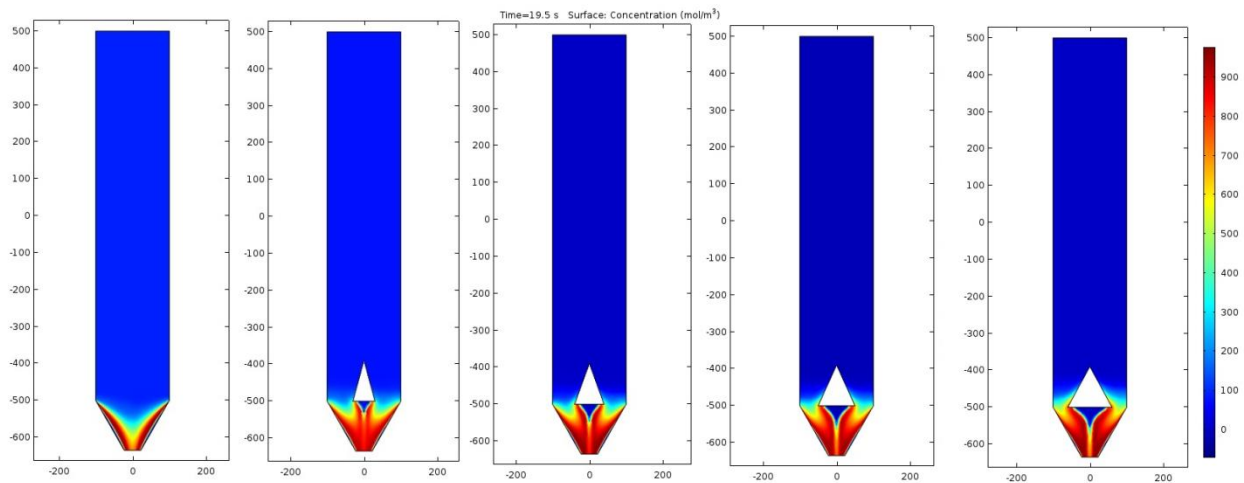

Figure 7. Results in case of 57,6° cone angle

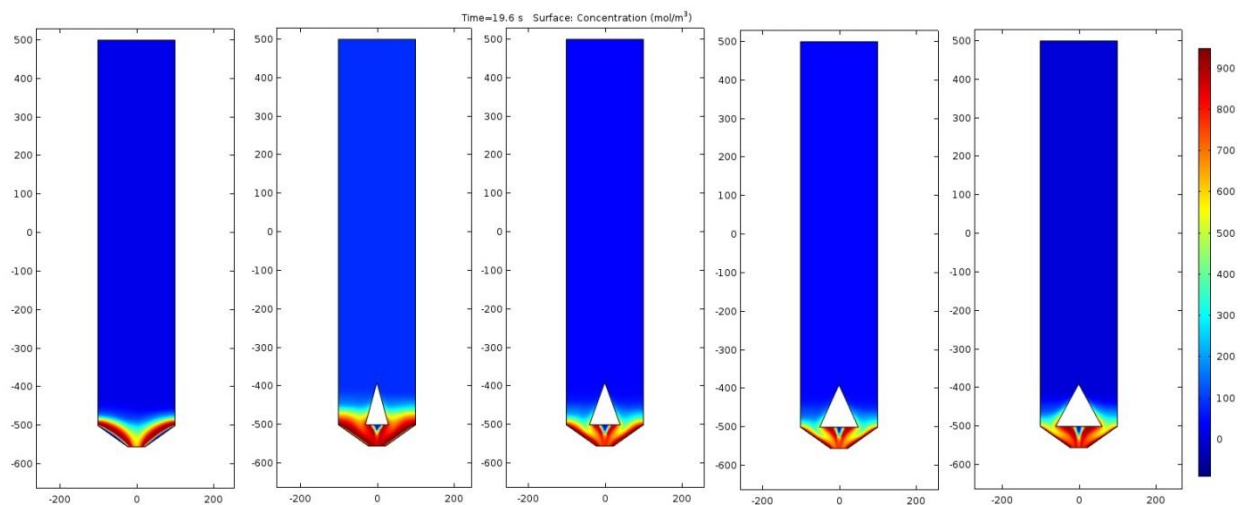

Figure 8. Results in case of 33,4° cone angle

There is also some concentration difference, or profile if we look at the wider inserts caused by the same dead zone formed below the triangular inserts. The 57.6° and 33.4° cone angle cases are presented in this paper.

In the next part, we would like to focus on the evaluation of the different inserts based on the residence time curves.

Figure 9 and 10 show the residence time curves with different insert width in case of 57.6° (Figure 9) and 33.4° (Figure 10) cone angle respectively. With the increase of the width of the insert, the maximum of the residence time curve shift left, leading to more uniform discharge. The residence time values and the deviance values are shown in Table 2 and Table 3 for 57.6° and 33.4° case respectively. The residence time values have minor differences in both the larger and the smaller cone angle cases. The differences could come to the fact, that the wider the insert, the smaller the flow region, so the minor difference could come only the volume decrease caused by the installation of the inserts.

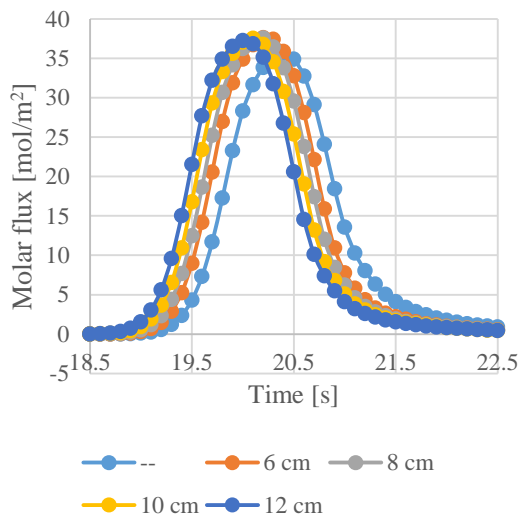

Figure 9. Residence time curves in case of 57,6° cone angle

Table 2 Residence time data in case of 57,6° cone angle

<i>Insert width</i>	Residence time [sec]	Standard deviance
--	10,39	1,484
6 cm	10,30	1,224
8 cm	10,27	1,239
10 cm	10,24	1,257
12 cm	10,20	1,273

We should also discuss the differences in the case of standard deviance. The lower the standard deviance

value, the lower the funnelling effect near the outlet of the silo. As we can see, the standard deviance values are always lower with the use of the inserts. There is a 16.6% decrease in the best insert for the larger cone angle and a 35.3 % decrease of the standard deviance in case of the smaller insert. There is a linear connection between the standard deviances in case of the smaller cone angle, the wider the insert, the lower the standard deviance, so the better the performance. The same correlation does not apply to the larger insert, where the minimum of the standard deviance was found in case of the 8 cm insert.

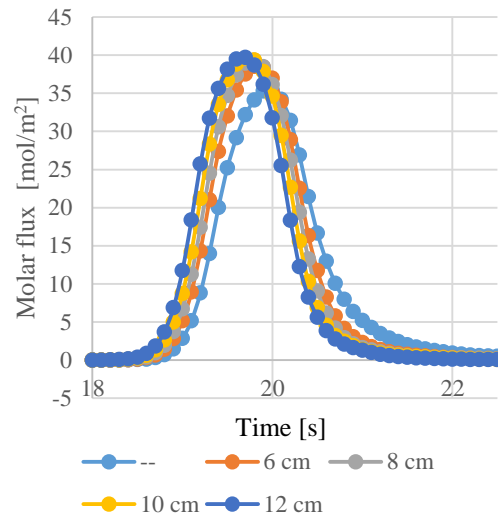

Figure 10. Residence time curves in case of 33,4° cone angle

Table 3 Residence time data in case of 33,4° cone angle

<i>Insert width</i>	Residence time [sec]	Standard deviance
--	10,17	1,293
6 cm	10,07	0,965
8 cm	10,04	0,930
10 cm	10,01	0,899
12 cm	9,98	0,837

Conclusions

In this study, a laboratory scale silo device was modelled. The device is a pseudo-2D type vessel which is suitable for video processing based model validation and model parameter evaluation. The effect of the different inserts and cone angles was tested both experimentally, and using COMSOL Multiphysics as a CFD simulator.

The detailed 2D CFD model of the silo was created using the CFD and Chemical Engineering module of COMSOL Multiphysics. The solid phase was treated

as a pseudoplastic fluid, calculation of the viscosity using a shear rate based equation. Stationary momentum and time-dependent component balances were calculated. After a mesh independence study, we identified the remaining model parameters and compared our results to the experimental results using residence times.

With the validated model the triangular inserts width was optimized. There is a 16.6% performance increase in the best insert for the larger cone angle, and a 35.3 % performance increase of the standard deviance in case of the smaller insert. In the future, the model can be used for further simulation studies. Facilitating the advantages of Livelink to MATLAB even more proper optimization can be performed, and the number and type of the inserts can be extended for rectangular or circular ones as well.

References

- [1] R. Nedderman, Statics and Kinematics of Granular Materials, Cambridge: Cambridge University Press, 1992.
- [2] J. Carson és D. Craig, „Silo design codes: Their limits and inconsistencies,” *Procedia Engineering*, 102, 647-656, 2015.
- [3] U. Tüzün és R.M.Nedderman, „Investigation of the effects of inserts on flow patterns inside a silo”, *Chemical Engineering Science*, 1983
- [4] G.H. Rong, S.C. Negi, J.C.Jofriet, „Simulation of Flow Behaviour of Bulk Solids in Bins, Part 2: Shear Bands, Flow Corrective Inserts and Velocity Profiles”, 1995
- [5] A.J. Waters , A. Drescher, „Modeling plug flow in bins/hoppers”, *Powder Technology* 113_2000. 168–175
- [6] J. Wu, J. Binbo, J. Chen, Y. Yang, „Multi-scale study of particle flow in silos”, *Advanced Powder Technology* 20 (2009) 62–73
- [7] M. Combarros Garcia, H.J. Feise, S. Strege, A. Kwade, „Segregation in heaps and silos: Comparison between experiment,simulation and continuum model”, *Powder Technology* 293 (2016) 26–36
- [8] S. Volpato, R. Artoni, A. C. Santomaso, „Numerical study on the behavior of funnel flow silos with and without inserts through a continuum hydrodynamic approach”, *Chemical Engineering Research and Design* 9 2 (2 0 1 4) 256–263

Acknowledgements

Attila Egedy's research was supported by EFOP-3.6.1-16-2016-00015 Smart Specialization Strategy (S3) -Comprehensive Institutional Development Program at the University of Pannonia to Promote Sensible Individual Education and Career Choices project. The financial support of MOL Nyrt. and Peregrinatio I. Foundations is gratefully acknowledged.