

Process simulation at Huntsman Advanced Materials

Dr.-Ing. Florian Klunker

COMSOL Conference, Lausanne, October 22-24, 2018

The logo for Huntsman, featuring the word "HUNTSMAN" in a bold, blue, sans-serif font. The text is centered between two horizontal red bars of equal length.

Enriching lives through innovation

A solid red vertical bar is positioned on the left side of the slide, extending from the top of the text area to the bottom.





Company Overview

As of June 30, 2018

Huntsman Businesses



Enriching lives through innovation

Polyurethanes	Performance Products	Advanced Materials	Textile Effects
<p>MDI</p> <p>Polyols</p> <p>PO/MTBE</p> <p>TPU</p> <p>PU Systems</p>	<p>Amines</p> <p>Surfactants</p> <p>Maleic Anhydride</p> <p>Upstream Intermediates</p>	<p>Composites</p> <p>Adhesives</p> <p>Resins</p>	<p>Dyes</p> <p>Chemicals</p> <p>Inks</p> <p>—</p> <p>Apparel</p> <p>Home & Institutional</p> <p>Technical Textiles</p>
			

Advanced Materials

Global Presence

Operating >75 Manufacturing, R&D and Operations Facilities in ~30 Countries⁽¹⁾

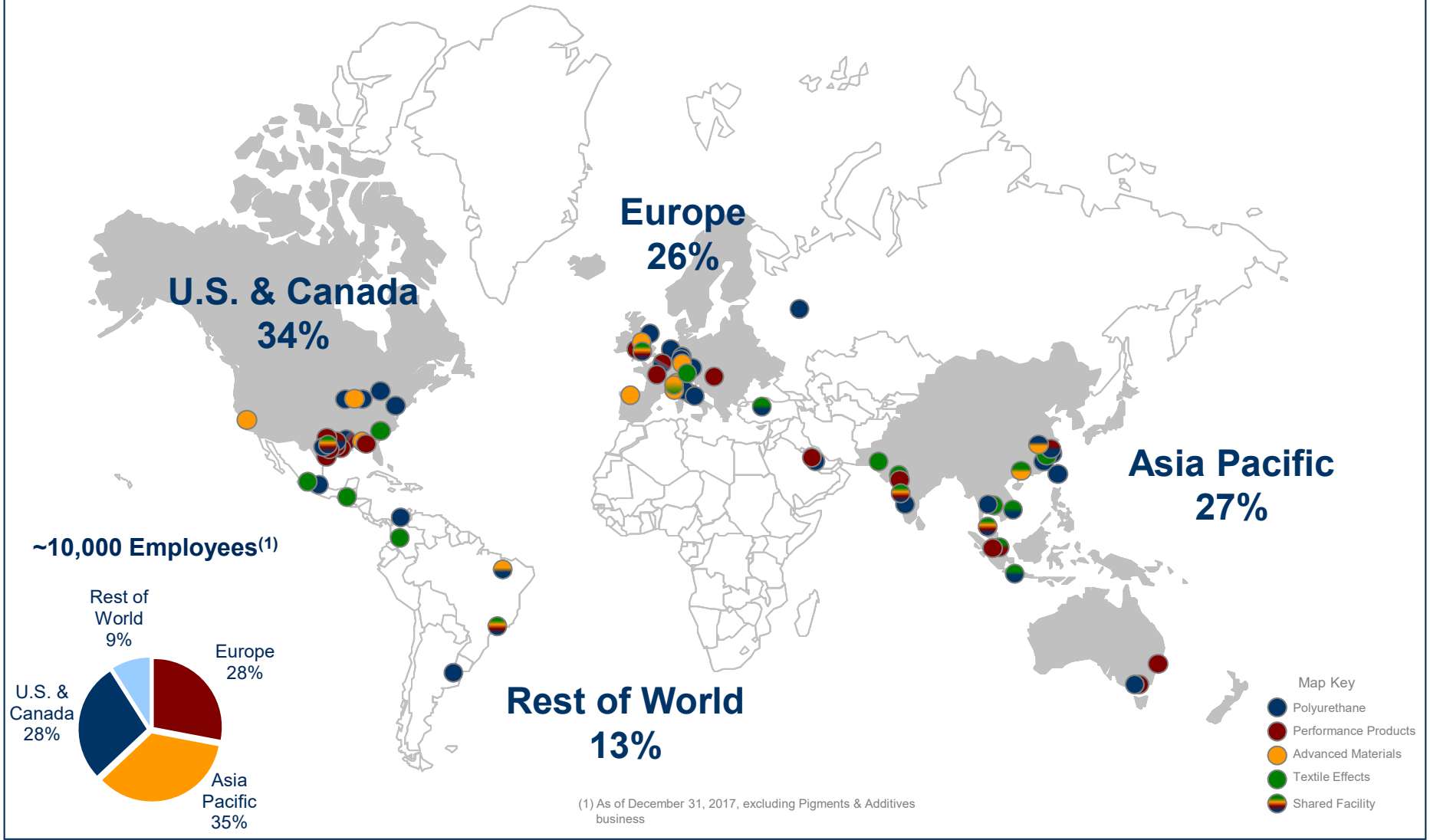

Huntsman Advanced Materials

Supporting high growth industries



Automotive



Aerospace



Adhesives

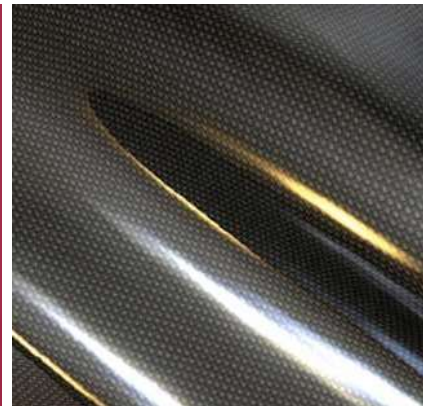

Composites

Huntsman Advanced Materials

Serving GDP-driven industries

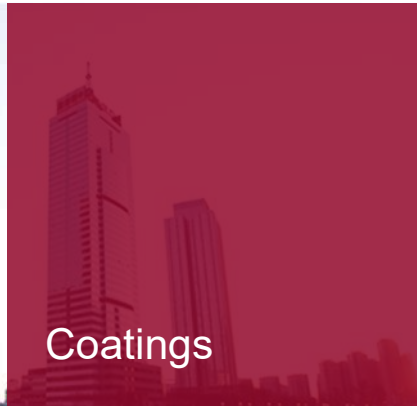

Coatings



Electronics



Wind



Power

Process simulation in Huntsman Advanced Materials

Overview

Process simulation within Huntsman Advanced Materials

- Long history, mainly in resin casting (neat resin and filled resins)
- Since 5 years:
Increased activity in simulation of composite manufacturing

Objective: support customers & development
resin selection
process optimization

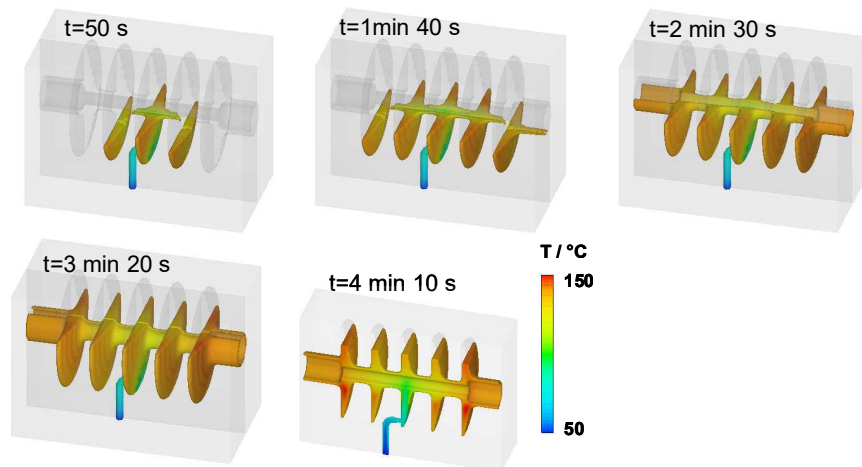

Filling of an insulator



Insulator for power applications

Steps of process simulation



- Experiments, e.g.
 - DSC
 - Rheology

- Material modelling by data fitting

- FEM – analysis
 - Cure simulation
 - Flow simulation

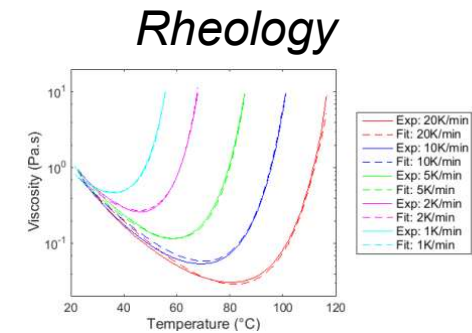
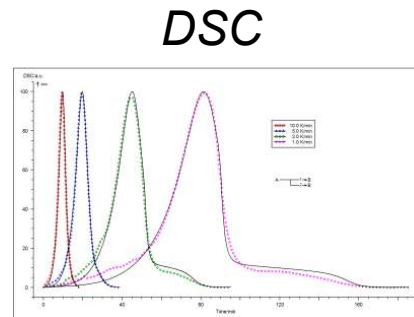

Material database

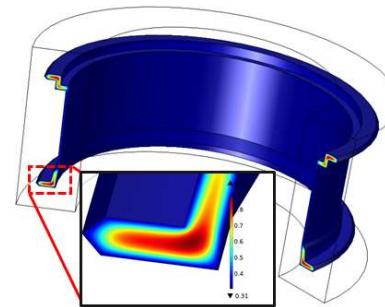

Cure simulation

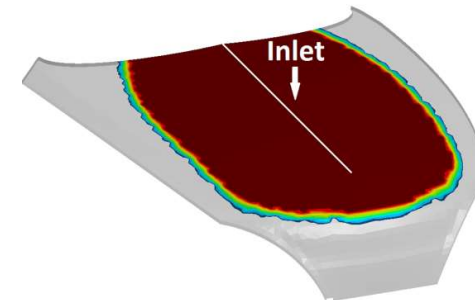

Flow simulation

Make material behaviour visible

Example cure simulation

- Cure characterization → Processing map
- Simulation - outcomes:
 - Prediction of temperature distributions
 - Evolution of material properties
 - Process optimization

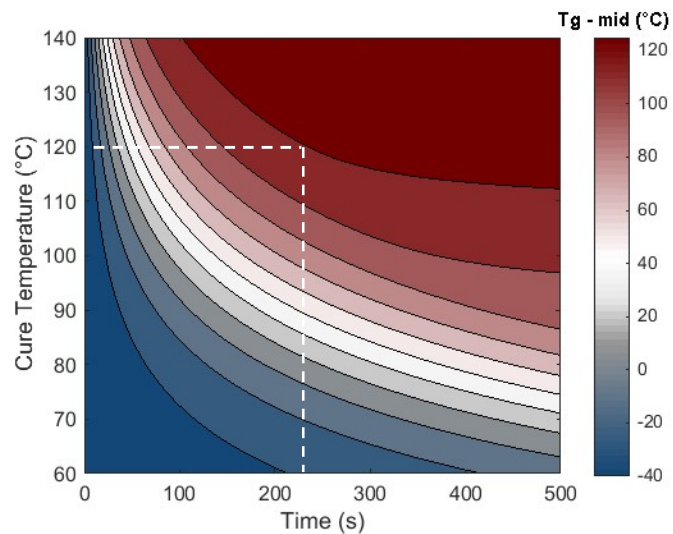

Example of Processing map : $T_g = f(T, t)$

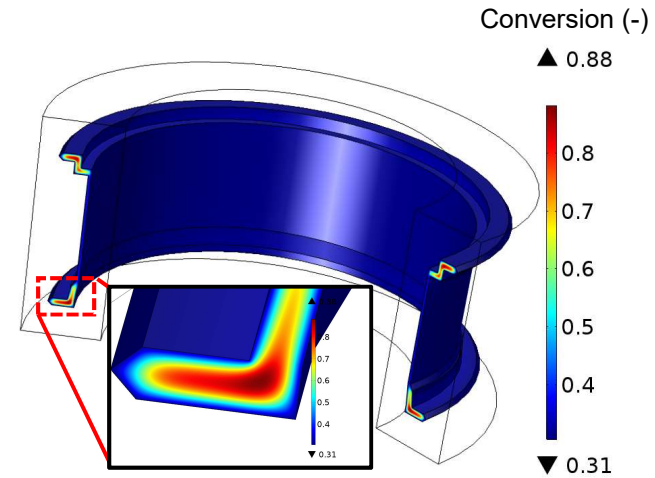

Conversion profile in *RIM-preform*

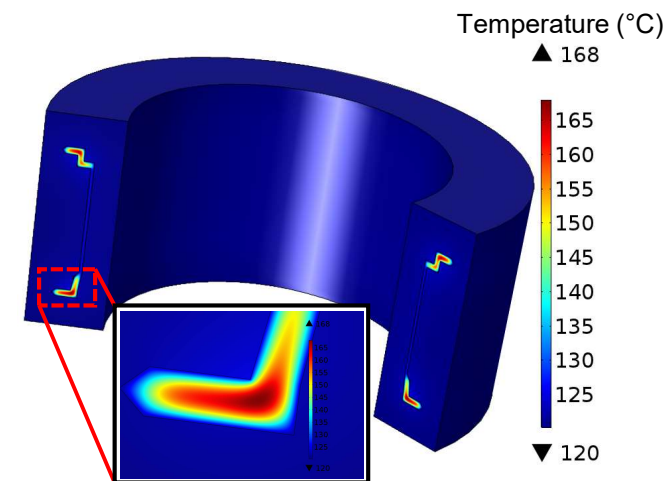

Temperature profile in *RIM-preform&tool*

Using simulation as a “GPS – System”

Example pressure vessels

- Type IV pressure vessels: Thermoplastic inliners set temperature limitations during cure of composite
- Simulation allows
 - Fast resin selection
 - Optimize production - Minimization of curing time
 - Identification of processing issues / proposal of alternatives

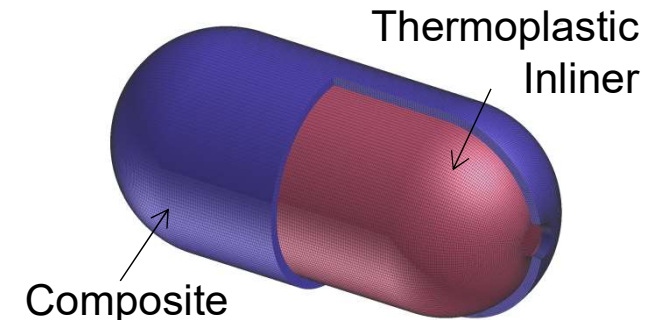

Schematic of a type IV pressure vessel

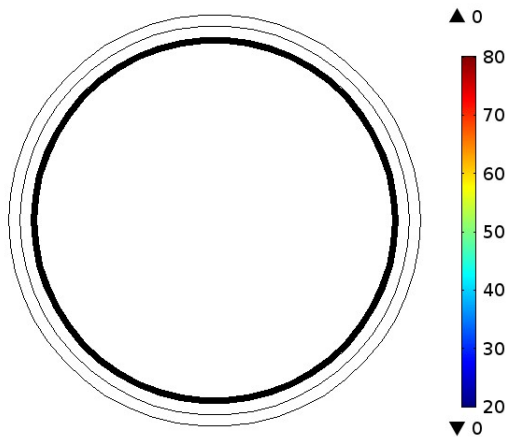

Example of simulation of filament winding and cure

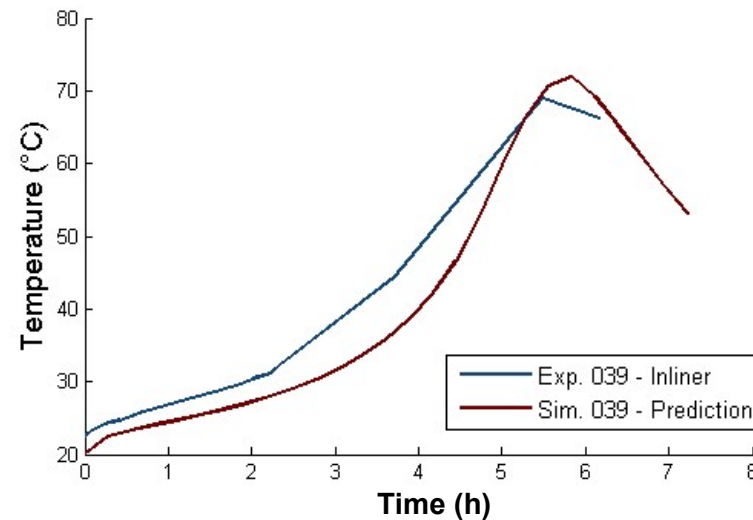

Example of customer trials

Virtual experiment platform

Example of flow simulation

Assessment of process robustness

- Flow pattern analysis
- Injection concepts evaluation
- Process parameter determination
- Quantification of processing flaws' impact

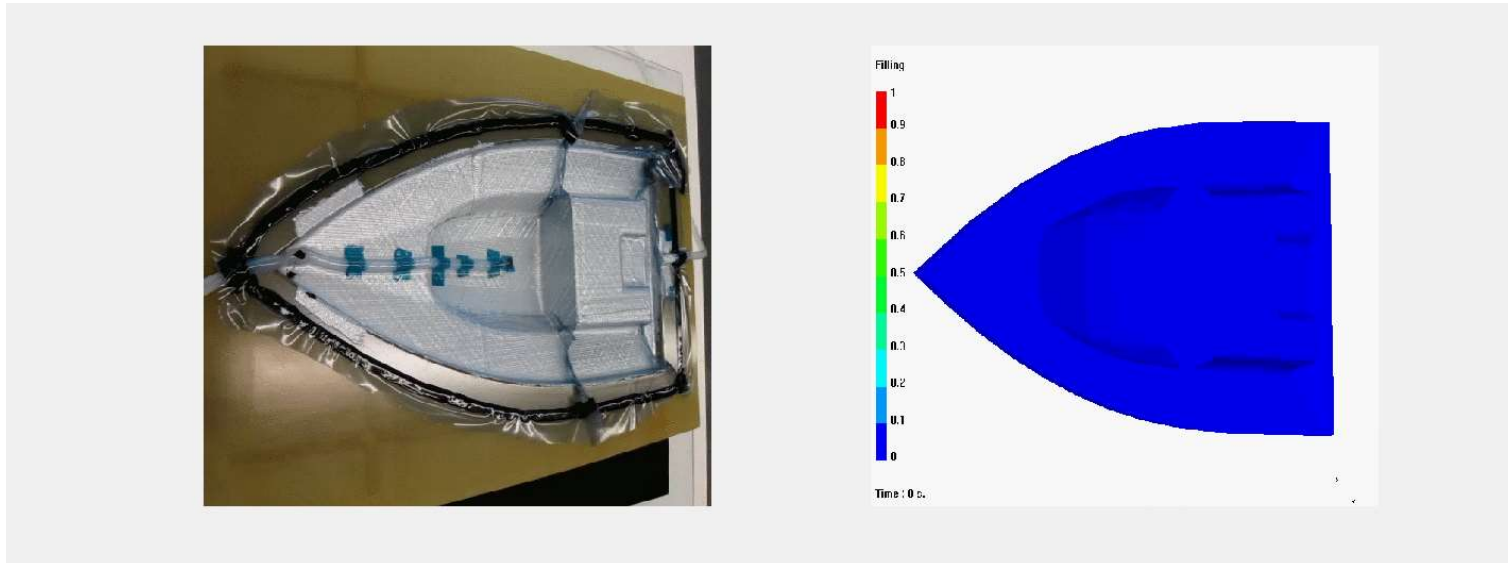

Video/simulation of vacuum infusion trial with local runners

Huntsman's simulation app on i-Tunes

For iPad: Quiz on composite processing



<https://itunes.apple.com/gb/app/huntsman-composites-processes/id1083084457?mt=8>

Use of COMSOL Server™ applications within Huntsman Advanced Materials

Distribution of know-how

HUNTSMAN

Enriching lives through innovation

- Any model can be transformed into an app
- Easy start for new users:
 - «Few click – simulations»
 - Integrated database
- World-Wide access via web-browser
- Low invest for large reachable user group

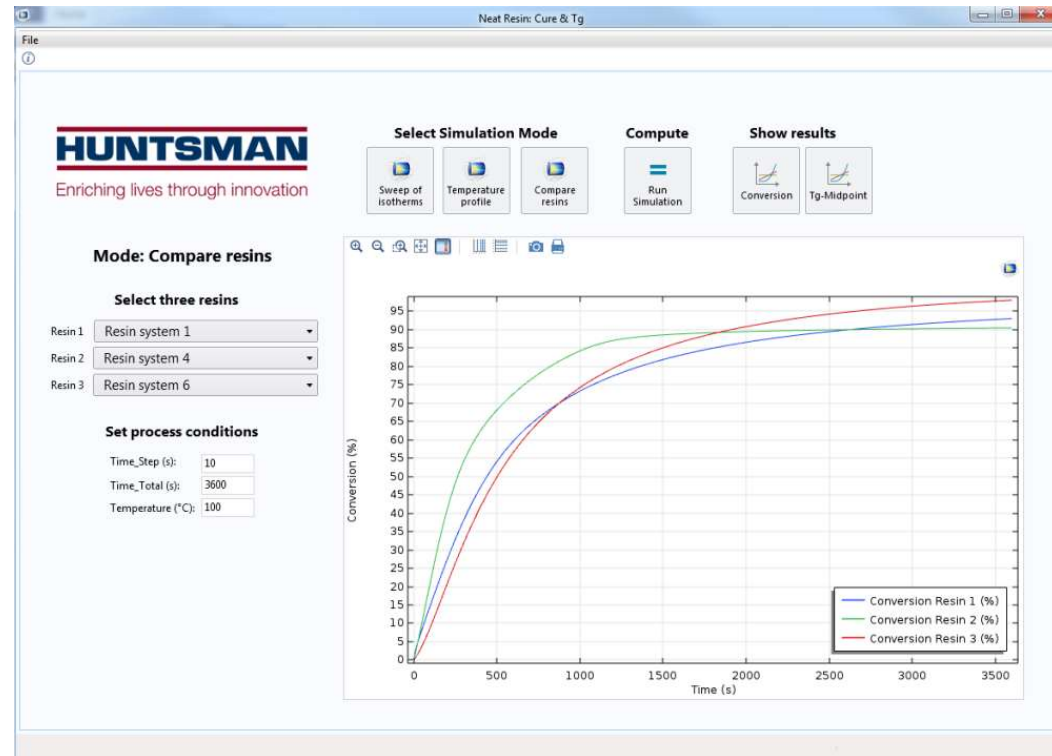

Simple apps for sharing know-how

Benefits for the user

- **Learning & Development:**
 - What are key parameters? What is their impact?
 - What is the best material and process solution for my customer?
- **Increase efficiency :**
 - Virtual experimental platform: less trials
 - Quick and unified reporting: templated output
 - Empowering users → Workflow - optimization

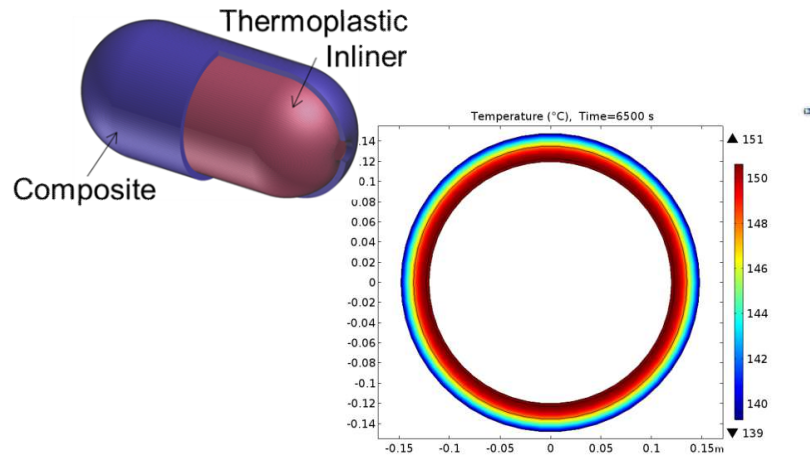

*How to design cure processes
for pressure vessels?*

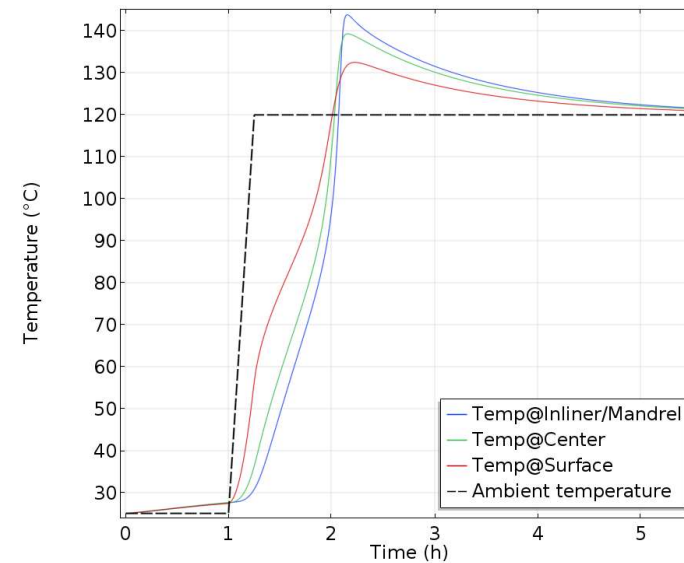

*Understanding the impact of
process parameters*

Benefit for expert: focus on innovation

New processes - specialized models

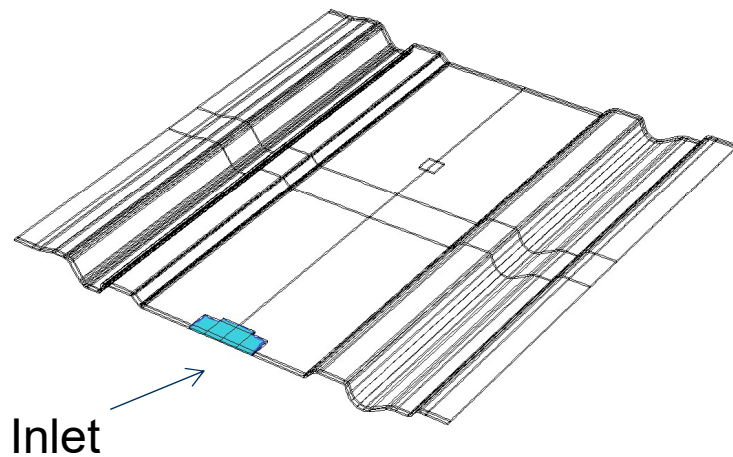

*Flow simulation using a variable catalyst concentration
colors: catalyst concentration
(US2017/0081487 A1)*

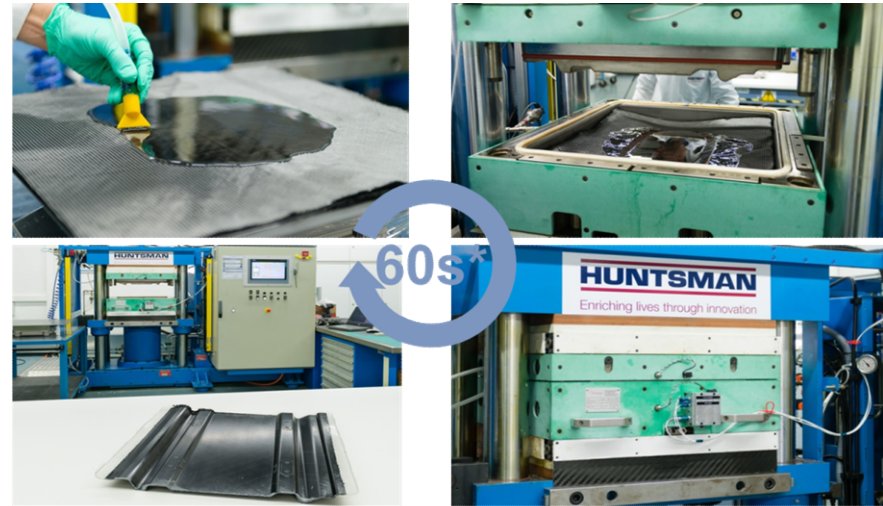

- Simple and fast
- * down to 60 second total process time based on experimental product

*Dynamic Fluid Compression Molding:
(WO2016/134937 A1)*

Benefit for expert: focus on innovation

New materials



Enriching lives through innovation

- **MIRALON™ products**
a new class of advanced carbon based performance materials

Sheets

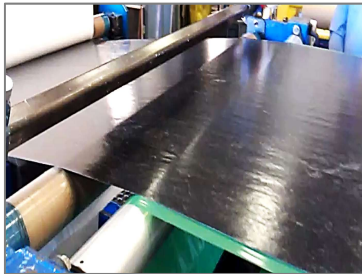

Tapes



Yarns



Dispersions

Available formats



Single step "Fuel To Product" process

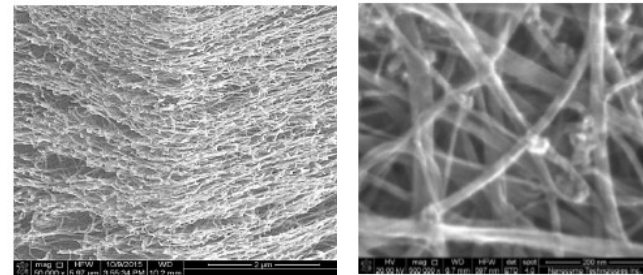

Material Structure

Benefit for expert: focus on innovation

New materials



Enriching lives through innovation

- MIRALON™ products - some properties & examples of applications

Radiative heaters



Electrical conductivity

ESD - adhesives

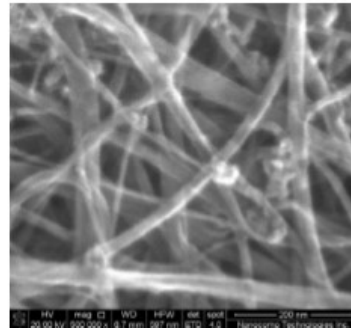

Lightweight potential

Thermal conductivity

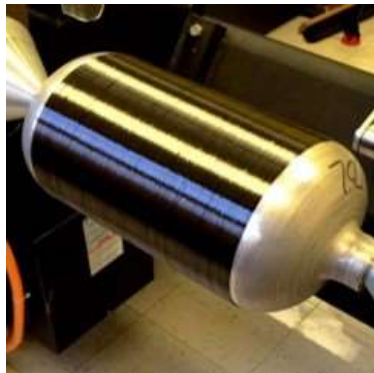

Composites

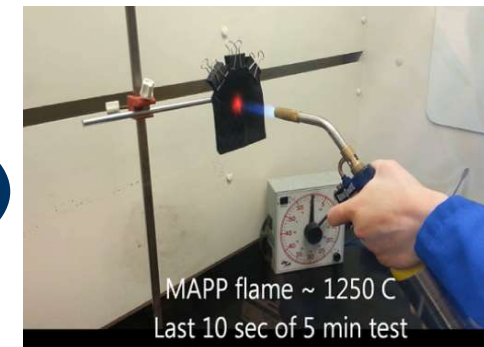

Fire protection barrier

Thank you for your attention



Contact details:

Dr.-Ing. Florian Klunker
Team Leader Simulation and Knowledge Management
Huntsman Advanced Materials
Klybeckstrasse 200
4057 Basel, Switzerland
Email: florian_klunker@huntsman.com

Huntsman warrants only that its products meet the specifications agreed with the buyer. Typical properties, where stated, are to be considered as representative of current production and should not be treated as specifications. While all the information and recommendations in this publication are to the best of our knowledge, information and belief accurate at the date of publication, NO GUARANTY, WARRANTY OR REPRESENTATION IS MADE, INTENDED OR IMPLIED AS TO THE CORRECTNESS OR SUFFICIENCY OF ANY INFORMATION OR RECOMMENDATION OR AS TO THE MERCHANTABILITY, SUITABILITY OR FITNESS OF ANY PRODUCTS FOR ANY PARTICULAR USE OR PURPOSE. IN ALL CASES, IT IS THE RESPONSIBILITY OF THE USER TO DETERMINE THE APPLICABILITY OF SUCH INFORMATION AND RECOMMENDATIONS AND THE SUITABILITY OF ANY PRODUCT FOR ITS OWN PARTICULAR PURPOSE. NOTHING IN THIS PUBLICATION IS TO BE CONSTRUED AS RECOMMENDING THE INFRINGEMENT OF ANY PATENT OR OTHER INTELLECTUAL PROPERTY RIGHT AND NO LIABILITY ARISING FROM ANY SUCH INFRINGEMENT IS ASSUMED. NOTHING IN THIS PUBLICATION IS TO BE VIEWED AS A LICENSE UNDER ANY INTELLECTUAL PROPERTY RIGHT.

MIRALON™ is a trademark of Huntsman Corporation or an affiliate thereof.
COMSOL® and COMSOL Server™ are trademarks of COMSOL AB.

© Copyright 2018. Huntsman Corporation or an affiliate thereof. All rights reserved.